

PRODUCT CATALOGUE
AND GLAZING GUIDELINES

This delivery programme shows our current products. We also produce a range of special solutions. Just ask.

We reserve the right to make changes to the technical specifications, the delivery programme and our product information. The relevant legal specifications are to be observed and complied with for all applications. Please ensure compliance with our special glazing guidelines; failure to do so will result in the voiding of our warranty.

If in doubt, please contact us.

The contents of this delivery programme were compiled in accordance with the best of our knowledge. No legal claims can be derived from it. This edition supersedes all previous versions.

Version 7.2025
Copyright:
SiLATEC reserves all its property and copyrights over the entire document including its components (drawings, pictures etc.)

PRODUCT RANGE	Burglar resistance	5
	Anti Reflective	5
	Private Protection	5
	Bullet resistance	6
	Glazing for panic doors	13
	steptec / corner glazing	16
	show case / display cabinet	17
GLAZING DIRECTIVE	Preconditions	20
	Checks	22
	Blocks	24
	Alarm	26
	Pay attention	28
	Take Care (Tc)	30
	Anti Reflective	31
	Conversion table	33

All values are subject to the normal tolerances. Our special glazing guidelines requires observance and compliance.

(mm) These depend on the size of the pane loads (e.g. wind load) directives and specifications.

(kg/m²)

mono,i2,i3 monolithic, insulating glass, triple insulating glass

U Thermal transmission coefficient The lower the value, the better the thermal insulation.

Kr Krypton

Ar Argon

T_L Light transmittance. The larger the value, the more light passes through the glazing.

g Total (solar) energy transmittance. The lower the value, the less energy passes through the glazing.

R_w Sound insulation index. The larger the value, the better the noise / sound insulation. The specified values are based on a krypton filling.

AS Alarm strip visible or invisible.

AW Alarm wire

SuS Sun protection coating

1) Test certificate
 2) Test certificate single pane
 3) Internally-ascertained estimate without test report
 4) Only invisible alarm strip is possible
 * Range of typical values

SILATEC Anti Reflective:
 anti reflective glass with a coated surface.
 Observe and comply with our "anti reflective" instructions.

BURGLARY PROTECTION											
Type	Name	Dimensions max. [mm]	Thickness [mm]	Weight [kg/m ²]	U* [W/m ² K]	T _L * [%]	g* [%]	R _w [dB]	Options		
									AS	AW	SuS
P6B + EH1											
mono	SILATEC P6B-EH1	2500 x 8000	17-25	30-50	4.7	80-90	70-80	40 ¹⁾	•	•	
i2	SILATEC P6B-EH1 i2	2500 x 8000	27-49	40-60	0.9-1.2	70-80	55-60	40-45	•	•	•
i3	SILATEC P6B-EH1 i3	2500 x 8000	39-61	55-80	0.5-0.8	65-70	45-50	40-45	•	•	•
P7B + EH2											
mono	SILATEC P7B-EH2	2500 x 8000	24-36	43-73	4.4	80-90	70-80	41 ¹⁾	•	•	
i2	SILATEC P7B-EH2 i2	2500 x 8000	34-60	53-93	0.9-1.2	70-80	55-60	40-45	•	•	•
i3	SILATEC P7B-EH2 i3	2500 x 8000	46-82	68-108	0.5-0.8	65-70	45-50	40-45	•	•	•
P8B + EH3											
mono	SILATEC P8B-EH3	2500 x 8000	24-32	39-59	4.0	80-90	70-80	43 ¹⁾	•	•	
i2	SILATEC P8B-EH3 i2	2500 x 8000	34-56	49-79	0.9-1.2	70-80	55-60	40-45	•	•	•
i3	SILATEC P8B-EH3 i3	2500 x 8000	46-78	64-94	0.5-0.8	65-70	45-50	40-45	•	•	•

ANTI REFLECTIVE											
anti reflective P6B + EH1											
mono	SILATEC P6B-EH1 anti reflective	2500 x 6000	21-25	40-50	4.7			40 ¹⁾			
	SILATEC P6B-EH1 anti reflective	2400 x 4800	21-25	40-50	4.7			40 ¹⁾	• ⁴⁾		
anti reflective P8B + EH3											
mono	SILATEC P8B-EH3 anti reflective	2500 x 6000	28-32	49-59	4.0			43 ¹⁾			
	SILATEC P8B-EH3 anti reflective	2400 x 4800	28-32	49-59	4.0			43 ¹⁾	• ⁴⁾		

PRIVATE PROTECTION											
i2	SILATEC private protection i2	2500 x 8000	33-55	56-86	0.9-1.4	70-80	55-60	40-45	•	•	•
i3	SILATEC private protection i3	2500 x 8000	45-77	70-110	0.5-0.8	65-70	45-50	40-45	•	•	•

All values are subject to the normal tolerances. Our special glazing guidelines requires observance and compliance.

(mm) These depend on the size of the pane loads (e.g. wind load)guidelines and specifications

NS No Spall

S Spall

mono, i2, i3 monolithic, insulating glass, triple insulating glass

U Thermal transmission coefficient. The lower the value, the better the thermal insulation.

Kr Krypton

Ar Argon

T_L Light transmittance. The larger the value, the more light passes through the glazing.

g Total (solar) energy transmittance. The lower the value, the less energy passes through the glazing.

R_w Sound insulation index. The larger the value, the better the noise / sound insulation. The specified values are based on krypton filling.

AS Alarm strip visible or invisible.

AW Alarm wire

SuS Sun protection coating

Tc Take care. The protective side is made of scratch-resistant plastic. Comply with our Take care (Tc) instructions.

1) Test certificate
 2) Test certificate for the individual pane
 3) Internally-ascertained estimate without test report
 4) Only invisible alarm strip is possible
 * Range of typical values

Fire protection:
 The combination of fire protection and bullet proofing is an object-related special solution. Proof of fire protection in the form of general building-authority approval is not available. As a result, approval of the entire (glass, frame, connection to the component) requires official approval on an individual basis. The fire protection glass is usually installed on the attack side. This results in an asymmetric glass structure. The direction of installation is to be agreed upon with the responsible authorities.

BULLET PROTECTION											
Type	Name	Dimensions max. [mm]	Thickness [mm]	Weight [kg/m ²]	U* [W/m ² K]	&	R _w [dB]	Options			Tc
								AS	AW	SuS	
BR 1											
NS mono	SILATEC BR1-NS 14/27	2000 x 3000	15	28	4.9	P6B ³⁾	40 ³⁾				•
NS i2	SILATEC BR1-NS 33/41	2000 x 3000	33	42	1.0 (Kr) /1.2(Ar)	P6B ¹⁾	43 ³⁾				
BR 2											
NS mono	SILATEC BR2-NS 18/35	2000 x 3000	19	35	4.7	P7B ³⁾	40 ³⁾				•
NS i2	SILATEC BR2-NS 28/44 [MSS]	Consulting	28	44	1.4 (Kr)/1.9 (Ar)	P6B ³⁾	38 ³⁾				•
	SILATEC BR2-NS 41/54	2000 x 3000	41	55	1.0 (Kr)/1.2 (Ar)	P7B ³⁾	43 ³⁾				
S mono	SILATEC BR2-S/P8B/EH3 27/46-AS	2500 x 4000	27	46	4.0	P8B ¹⁾	43 ¹⁾	•			
	SILATEC BR2-S/P8B/EH3 28/49	2500 x 4000	28	49	4.0	P8B ¹⁾	43 ¹⁾				
	SILATEC BR2-S/P8B/EH3 30/54-AS	2500 x 5000	30	54	4.0	P8B ¹⁾	43 ¹⁾	•			
BR 3											
NS mono	SILATEC B3-NS 20/40	2000 x 3000	21	40	4.7	P7B ³⁾	41 ³⁾				•
NS i2	SILATEC BR3-NS 48/60	2000 x 3000	48	61	1.0 (Kr) /1.2(Ar)	P8B ³⁾	43 ³⁾				
S i2	SILATEC BR3-S 38/55	2000 x 3000	38	55	1.0 (Kr)/1.2 (Ar)	P6B ¹⁾	43 ³⁾				

BULLET PROTECTION											
Type	Name	Dimensions max. [mm]	Thickness [mm]	Weight [kg/m ²]	U* [W/m ² K]	& ¹⁾²⁾³⁾	R _w [dB]	Options			Tc
								AS	AW	SuS	
BR 4											
NS mono	SILATEC BR4-NS 25/52	2450 x 4500	25	53	4.7	P6B ²⁾	42 ¹⁾				•
	SILATEC BR4-NS 30/61-AS	2450 x 4500	30	61	4.5	P7B ³⁾	42 ³⁾	•			•
NS i2	SILATEC BR4-NS 35/58	Consulting	35	58	1.1(Kr)/1.6(Ar)	P6B ³⁾	42 ³⁾			•	•
	SILATEC BR4-NS (25.52) 39/68 i2	2450 x 4500	39-43	68-73	1.1 (Kr)/1.6(Ar)	P6B ²⁾	40 ³⁾	•		•	•
	SILATEC BR4-NS 52/76	2000 x 3500	52	76	1.0 (Kr)/1.2(Ar)	P8B ²⁾	48 ¹⁾				
	SILATEC BR4-NS 54/82-AS	2000 x 4000	54	82	1.0 (Kr)/1.2(Ar)	P8B ³⁾	48 ³⁾	•			
NS i3	SILATEC BR4-NS (25.52) 53/83 i3	2450 x 4500	53-61	83-93	0.7(Kr)/0.9(Ar)	P6B ²⁾	40 ³⁾	•		•	•
	SILATEC BR4-NS 61/80-1010	2000 x 3000	61	80	0.5 (Kr)/0.8(Ar)	P8B ³⁾	45 ³⁾				
	SILATEC BR4-NS 69/100-1010-T-AS	2000 x 4500	69	100	0.5 (Kr)/0.8(Ar)	P8B ³⁾		•			
S i2	SILATEC BR4-S 42/64-12	2500 x 5000	42	64	1.0 (Kr)/1.2(Ar)	P6B ¹⁾	43 ³⁾			•	
	SILATEC BR4-S 44/69-12-AS	2500 x 5000	44	69	1.0 (Kr)/1.2(Ar)	P6B ¹⁾	44 ¹⁾	•		•	
S i3	SILATEC BR4-S 56/69-1212-T	2500 x 5000	56	69	0.5 (Kr)/0.7(Ar)	P6B ¹⁾	45 ¹⁾			•	
	SILATEC BR4-S 56/69-1212-T-AS	2500 x 5000	56	69	0.5(Kr)/0.7(Ar)	P6B ¹⁾	45 ¹⁾	•		•	
BR 5											
NS mono	SILATEC B5-NS 35/76	2000 x 4000	36	76	4.4	P7B ³⁾	43 ³⁾				•
NS i2	SILATEC B5-NS (35.76) 50/91 i2	2000 x 4000	50-54	91-96	1.1(Kr)/1.6(Ar)	P7B ³⁾	42 ³⁾	•		•	•
	SILATEC B5-NS 62/99	2000 x 3000	63	101	1.1 (Kr)/1.1(Ar)	P7B ³⁾	45 ³⁾				
NS i3	SILATEC B5-NS (35.76) 64/106 i3	2000 x 4000	64-72	106-116	0.7(Kr)/0.9(Ar)	P7B ³⁾	42 ³⁾	•		•	•

BULLET PROTECTION											
Type	Name	Dimensions max. [mm]	Thickness [mm]	Weight [kg/m ²]	U* [W/m ² K]	& ¹⁾²⁾³⁾	R _w [dB]	Options			Tc
								AS	AW	SuS	
BR 6											
NS mono	SILATEC BR6-NS 41/90	2450 x 4500	41	91	4.4	P7B ³⁾	43 ³⁾				•
	SILATEC BR6-NS 43/92-AS	2450 x 4500	43	92	4.4	P7B ³⁾	43 ³⁾	•			•
NS mono	SILATEC BR6-NS 53/114	1400 x 3000	53	114	4.4	P7B ³⁾	44 ³⁾				•
NS i2	SILATEC BR6-NS 52/97	Consulting	52	97	1.1(Kr)/1.5(Ar)	P7B ³⁾	44 ³⁾				•
	SILATEC BR6-NS 53/86	Consulting	53	86	1.0 (Kr)/1.2(Ar)	P8B ³⁾	44 ³⁾			•	•
	SILATEC BR6-NS (41.90) 55/106 i2	2450 x 4500	55-60	106-112	1.1 (Kr)/1.6(Ar)	P7B ³⁾	44 ³⁾	•		•	•
	SILATEC BR6-NS 69/122	2000 x 4000	69	122	1.0 (Kr)/1.1(Ar)	P8B ²⁾	48 ³⁾				
NS i3	SILATEC BR6-NS (41.90) 69/121 i3	2450 x 4500	69-78	122-132	0.7 (Kr)/0.9(Ar)	P7B ³⁾	44 ³⁾	•		•	•
	SILATEC BR6-NS 82/133-1010	2000 x 4000	82	133	0.5 (Kr)/0.8(Ar)	P8B ³⁾	46 ³⁾				
BR 7											
NS mono	SILATEC BR7-NS 63/127	1200 x 3200	63	126	4,5	P8B ³⁾	45 ³⁾				•
NS mono	SILATEC BR7-NS 75/163	1200 x 2550	75	163	4,5	P8B ³⁾	45 ³⁾				
NS i2	SILATEC BR7-NS (63.127) 77/142 i2	1200 x 3200	77	141	1,1 (Kr)/1,6(Ar)	P8B ³⁾	47 ³⁾	•		•	•
NS i2	SILATEC BR7-NS (75.163) 89/178 i2	1200 x 2550	89	178	1,1 (Kr)/1,6(Ar)	P8B ³⁾	47 ³⁾	•		•	
SG 1											
NS mono	SILATEC SG1-NS 25/43	1000 x 2200	26	44	4.0	P8B ³⁾	40 ³⁾				•
NS i2	SILATEC SG1-NS 57/79	2000 x 3500	57	80	1.0 (Kr)/1.0(Ar)	P7B ³⁾	45 ³⁾				
SG 2											
NS mono	SILATEC SG2-NS 31/52	1000 x 2200	31	52	4,0	P8B ³⁾	43 ³⁾				•
NS i2	SILATEC SG1-NS 64/95	2000 x 3500	64	96	1.0 (Kr)/1.0(Ar)	P8B ³⁾	48 ³⁾				

BULLET PROTECTION		SPECIAL CLASSIFICATIONS									
Type	Name	Dimensions max. [mm]	Thickn. [mm]	Weight [kg/m ²]	U* [W/m ² K]	& ¹⁾²⁾³⁾	R _w [dB]	Options			Tc
								AS	AW	SuS	
Kalashnikov AK 47 Iron core		VPAM Class 6		(Calibre: 7,62 x 39 mm; projectile: 8 g Fe-core)							
NS mono	SILATEC AK47-NS 36/76	2000 x 4000	36	76	4.4	BR5-NS ¹⁾ /P7B ³⁾	43 ³⁾				•
NS i2	SILATEC AK47-NS (36.76) 50/91 i2	2000 x 4000	50-54	91-96	1.1 (Kr) /1.6(Ar)	BR5-NS ¹⁾ /P7B ³⁾	40 ³⁾	•		•	•
NS i3	SILATEC AK47-NS (36.76) 64/106 i3	2000 x 4000	64-72	106.116	0.7 (Kr) /0.9(Ar)	BR5-NS ¹⁾ /P7B ³⁾	40 ³⁾	•		•	•
Kalashnikov AK 47 Hard core + incendiary composition		NATO STANAG 4569 Level 2		(Calibre: 7,62 x 39 mm; projectile: 7,77 g API)							
NS mono	SILATEC AK47-NS 62/141	2000 x 4000	64	144	4.1	P7B ³⁾	47 ³⁾				•
NS i2	SILATEC AK47-NS (62.141)76/157 i2	2000 x 4000	76-80	157-167	1.1 (Kr) /1.6(Ar)	P7B ³⁾	43 ³⁾	•		•	•
NS i3	SILATEC AK47-NS (62.141)90/171 i3	2000 x 4000	90-94	171-181	1.1 (Kr) /1.6(Ar)	P7B ³⁾	43 ³⁾	•		•	•
Dragunov Hard core		Russian GOST Level 5		(Calibre: 7,62 x 54 R; projectile: 10,4 g AP)							
NS i2	SILATEC Gost 2014 - 5NS 95/203 i2	2450 x 4000	95	203	2.2 (kr)/2.3(Ar)	P8B ³⁾	45 ³⁾				•
NS i2	SILATEC Gost 2014 - 5NS 99/200 i2	1200 x 2550	100	204	1.1 (kr)/1.5(Ar)	P8B ³⁾	45 ³⁾			•	

All values are subject to the normal tolerances. Our special glazing guidelines requires observance and compliance.

(mm) These depend on the size of the pane loads (e.g. wind load) guidelines and specifications.

(kg/m²)

mono,i2,i3 monolithic, insulating glass, triple insulating glass

U Thermal transmission coefficient. The lower the value, the better the thermal insulation.

Kr Krypton

Ar Argon

T_L Light transmittance. The larger the value, the more light passes through the glazing.

g Total (solar) energy transmittance. The smaller the value, the less energy enters through the glazing.

R_w Sound insulation index. The larger the value, the better the noise / sound insulation. The specified values are based on krypton filling.

AS Alarm strip visible or invisible.

AW Alarm wire

SuS Sun protection coating

1) Test certificate
 2) Test certificate single pane
 3) Internally-ascertained estimate without test report
 4) Only invisible alarm strip is possible
 * Range of typical values

Test RC2 and RC3:
 The inspected laminated glass structure satisfies the requirements in terms of resistance against manual break-in attempts (attack on the surface of the panic glazing) in the resistance classes RC2 and RC3 in accordance with EN 1627 / 1630 for use in door elements for escape routes.

Test RC4 D:
 The inspected laminated glass structure was tested in accordance with the test requirements of the resistance class RC4 in accordance with DIN EN 1627/1630. Within the resistance time specified, it prevents the creation of a square, attackable opening with a side length of 120 mm. The interior operating elements must be arranged and secured in such a way that they cannot be reached and activated through the opening in the glass using the tool sets stated in the standard.

Fire protection:
 The combination of fire protection and panic glazing is an object-related special solution. Proof of fire protection in the form of general building-authority approval is not available. As a result, approval of the entire (glass, frame, connection to the component) requires official approval on an individual basis. The fire protection glass is usually installed on the attack side. This results in an asymmetric glass structure. The direction of installation is to be agreed with the responsible authorities.

GLAZING FOR PANIC DOORS										
Type	Name	Dimensions max. [mm]	Thickness [mm]	Weight [kg/m ²]	U* [W/m ² K]	R _w [dB]	Options			
							AS	AW	SuS	TC
RC2 panic										
mono	SILATEC RC2 panic 16/29	2000 x 3000	16	29	4.7	40 ¹⁾		•		
i2	SILATEC RC2 panic 32/44 i2	2000 x 3000	32	44	1.0 (Kr) /1.14(Ar)	41 ³⁾	•	•	•	
i2	SILATEC RC2 panic 46/67 i2	1400 x 3000	46	76	1.0 (Kr) /1.3(Ar)	42 ³⁾	•		•	
i2	SILATEC RC2 panic 55/95 i2	1400 x 3000	55	95	1.0 (Kr) /1.3(Ar)	43 ³⁾	•		•	
i2	SILATEC RC2 panic 68/127 i2	1400 x 2850	68	127	1.0 (Kr) /1.3(Ar)	45 ³⁾	•		•	
i3	SILATEC RC2 panic 44/59 i3	2000 x 3000	44	59	0.6 (Kr) /0.9(Ar)	43 ³⁾	•	•	•	
RC3 panic										
mono	SILATEC RC3 panic 28/53	2000 x 3000	28	53	4.2	42 ¹⁾		•		
mono	SILATEC RC3 panic BR4-NS 33/56	2000x3000	34	59	4,2	43 ³⁾		•		•
i2	SILATEC RC3 panic 38/59 i2	2000 x 3000	38	59	1.1 (Kr) /1.6(Ar)	42 ¹⁾	•	•		
i2	SILATEC RC3 panic 44/68 i2	2000 x 3000	44	68	1.0 (Kr) /1.3(Ar)	43 ¹⁾	•	•	•	
	SILATEC RC3 panic BR4-NS 50/74 i2	2000x3000	50	74	1.0 (Kr) /1.3(Ar)	43 ³⁾	•	•	•	•
i2	SILATEC RC3 panic 57/97 i2	1400 x 3000	57	97	1.0 (Kr) /1.3(Ar)	44 ³⁾	•		•	
i2	SILATEC RC3 panic 66/116 i2	1400 x 3000	66	116	1.0 (Kr) /1.3(Ar)	45 ³⁾	•		•	
i2	SILATEC RC3 panic 79/148 i2	1400 x 2850	79	148	1.0 (Kr) /1.3(Ar)	47 ³⁾	•		•	
i3	SILATEC RC3 panic 56/83 i3	2000 x 3000	56	83	0.6 (Kr) /0.9(Ar)	45 ¹⁾	•	•	•	
i3	SILATEC RC3 panic BR4-NS 62/89 i3	2000 x 3000	62	89	0.6 (Kr) /0.9(Ar)	45 ³⁾	•	•	•	•

GLAZING FOR PANIC DOORS										
Type	Name	Dimensions max. [mm]	Thickness [mm]	Weight [kg/m ²]	U* [W/m ² K]	R _w [dB]	Options			
							AS	AW	SuS	TC
RC4 panic D										
mono	SILATEC RC4 panic D 41/69	2000 x 3000	40	69	3.5	44 ³⁾		•		
mono	SILATEC RC4 panic BR4-NS 46/75	2000 x 3000	46	75	3,5	44 ³⁾		•		•
i2	SILATEC RC4 panic D 57/84 i2	2000 x 3000	54	84	1.0 (Kr) /1.4(Ar)	44 ³⁾	•	•	•	
i2	SILATEC RC4 panic BR4-NS 60/90 i2	2000 x 3000	60	90	1.0 (Kr) /1.4(Ar)	44 ³⁾		•		•
i2	SILATEC RC4 panic D 69/116 i2	1400 x 3000	68	116	1.0 (Kr) /1.4(Ar)	45 ³⁾	•		•	
i2	SILATEC RC4 panic D 78/135 i2	1400 x 3000	77	135	1.0 (Kr) /1.4(Ar)	45 ³⁾	•		•	
i2	SILATEC RC4 panic D 91/167 i2	1400 x 2850	90	167	1.0 (Kr) /1.4(Ar)	46 ³⁾	•		•	
i3	SILATEC RC4 panic D 69/99 i3	2000 x 3000	68	99	0.6(Kr) /0.9(Ar)	46 ³⁾	•	•	•	

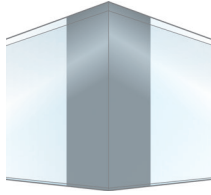
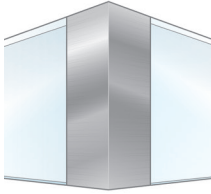
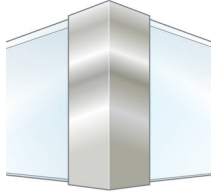
STEP-TEC		
Type	Description	Depiction
SILATEC STEP-TEC GG		
Burglary Protection P6B, P7B, P8B Mono, i2, i3 Private protection	Angle 60°-180° The entire corner is made of glass and the corner area is enamelled with a cap edge.	
SILATEC STEP-TEC GMG		
Burglary Protection P6B, P7B, P8B Mono, i2, i3 Private protection	Angle 60°-180° Metal profile, flush with the glass surface. Subtle shadow gap between glass and metal. Stainless steel, brass, bronze, mat, brushed, high gloss polished.	
SILATEC STEP-TEC M		
Burglary Protection P6B, P7B, P8B Mono, i2, i3 Private protection	Angle 60°-180° Metal profile, screwed from inside outwards. Acceptance of particularly high forces. Stainless steel, brass, bronze, mat, brushed, high gloss polished.	

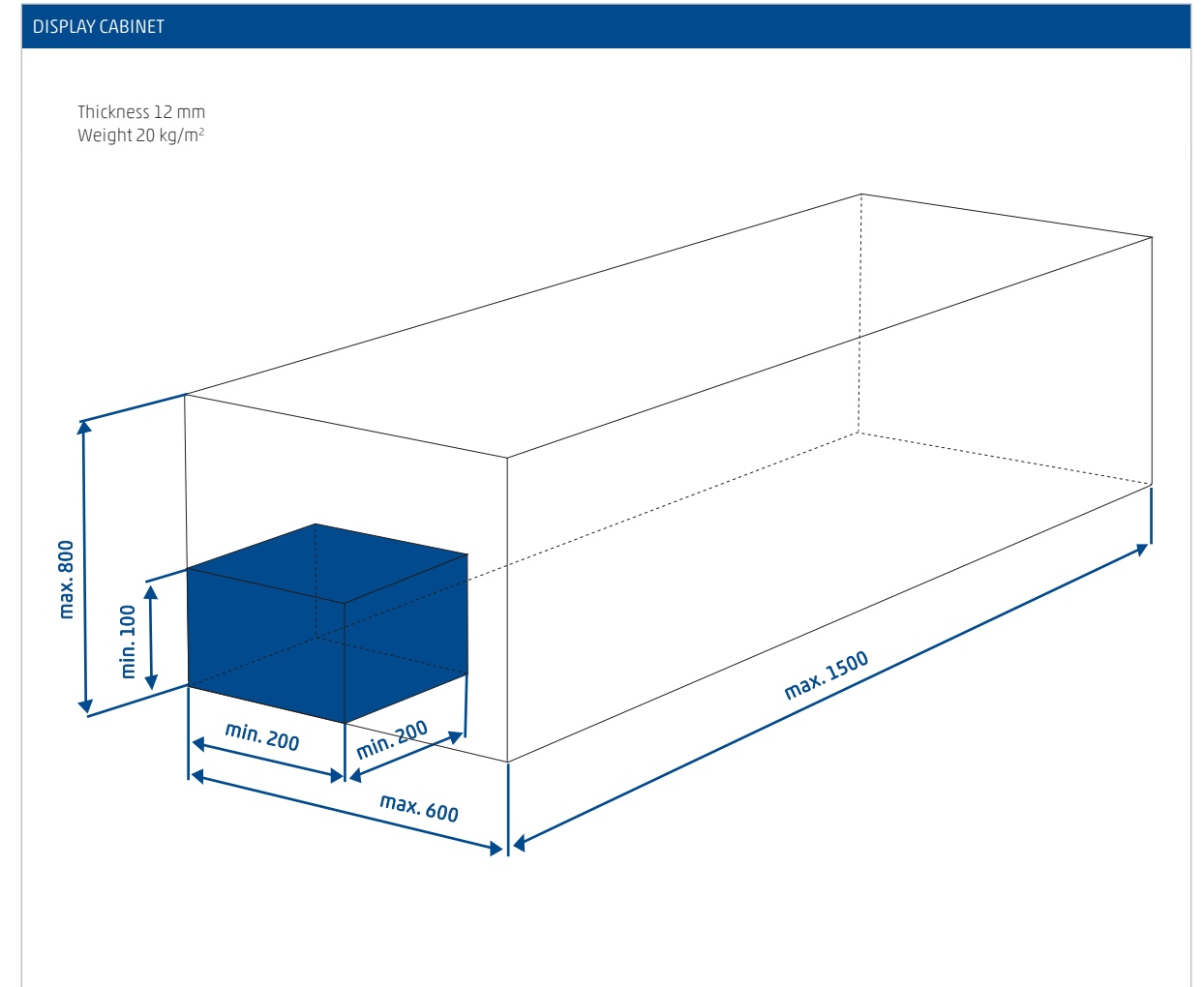

The SiLATEC glazing guidelines are purposefully short so as to cover only the most important matters.

The generally recognized rules of engineering and glazing and legal prescriptions and safety rules are also to be observed and complied with.

Compliance with our glazing directives does not in any way relieve the operator of compliance with official prescriptions, laws or directives and the attainment of the necessary permissions and approval.

The installation may only be performed by trained specialists.

Our warranty requires compliance with our glazing guidelines and all generally-valid technical rules. No alterations may be made to the panes and the panes may not be damaged in any location.

If in doubt, please contact us.

The contents of these glazing guidelines were compiled in accordance with the best of our knowledge. No legal claims can be derived from them. This edition supersedes all previous editions. Version 2.2020

Copyright:
SiLATEC reserves all its property and copyrights over the entire document including its components (drawings, pictures etc.).

- 1 EXPANSION JOINT:** SILATEC security glass has a circumferential "expansion joint", so that the various materials can expand without hindrance upon heating. This "expansion joint" must not be permitted to become blocked.
- 2 EDGE COATING:** The full extent of the surrounding edge coating (c. 8-12 mm) must be covered.
- 3 GLAZING REBATE ROOM:** The glazing rebate room must be kept permanently clean and free of oil / grease residue as well as any adhesives / sealants. It must be open around its full extent and amount to 5 mm in each location.
- 4 VENTILATED GLAZING REBATES:** The frame system must be able to remove the condensate developing in the glazing rebate room immediately. The ventilated glazing rebate faces the side with the colder and drier climate and prevents the penetration of rain water.
- 5 ALARM CABLE INSTALLATION:** Provide sufficient space for the installation and strain-relief of the alarm cable. A minimum of 7 mm in the glazing rebate room must be kept open for the alarm socket. The cable and socket must not be subject to damage, jamming or kinking.
- 6 DEPTH OF GLASS IN REBATE:** The depth of the glass in the rebate must be dimensioned so that the glazing remains securely in the frame under all forces (e.g. wind force). We recommend a minimum of 15 mm. Depths of up to 30 mm in the rebate has proven to be successful given special safety requirements. The pane is to be stored in linear fashion, supported on all sides.
- 7 JOINT:** With flat panes, c. 3-6 mm on both sides. With cylindrically curved panes, c. 10-20 mm on both sides to compensate for tolerances. Ensure material compatibility with the glazing and the frame.
- 8 DISTANCE TAPE** The distance tape prevents contact between the glass and the frame.
- 9 MAXIMUM TEMPERATURE:** < 60°C laminated glass
< 50°C laminated glass with fire protection function
- CYLINDRICALLY CURVED PANES:** No forces may be allowed to impinge on cylindrically curved panes. It must be subject to zero stress on all sides, without pressure points in the glazing rebate room. This explains why dry and pressure glazing is not permissible. Wet sealing (silicone) compensates tolerances and avoids pressure points.
- PRESSURE GLAZING:** Pressure glazing must guarantee a linear, elastic storage along the glass edge under the occurring loads. The contact pressure should be equal and may not exceed 15N/cm. Point loading is not permissible.
- WARPAGE RESTRICTION:** The warpage restriction of the framework profile may amount to a maximum of l/200 and may not exceed 15 mm.

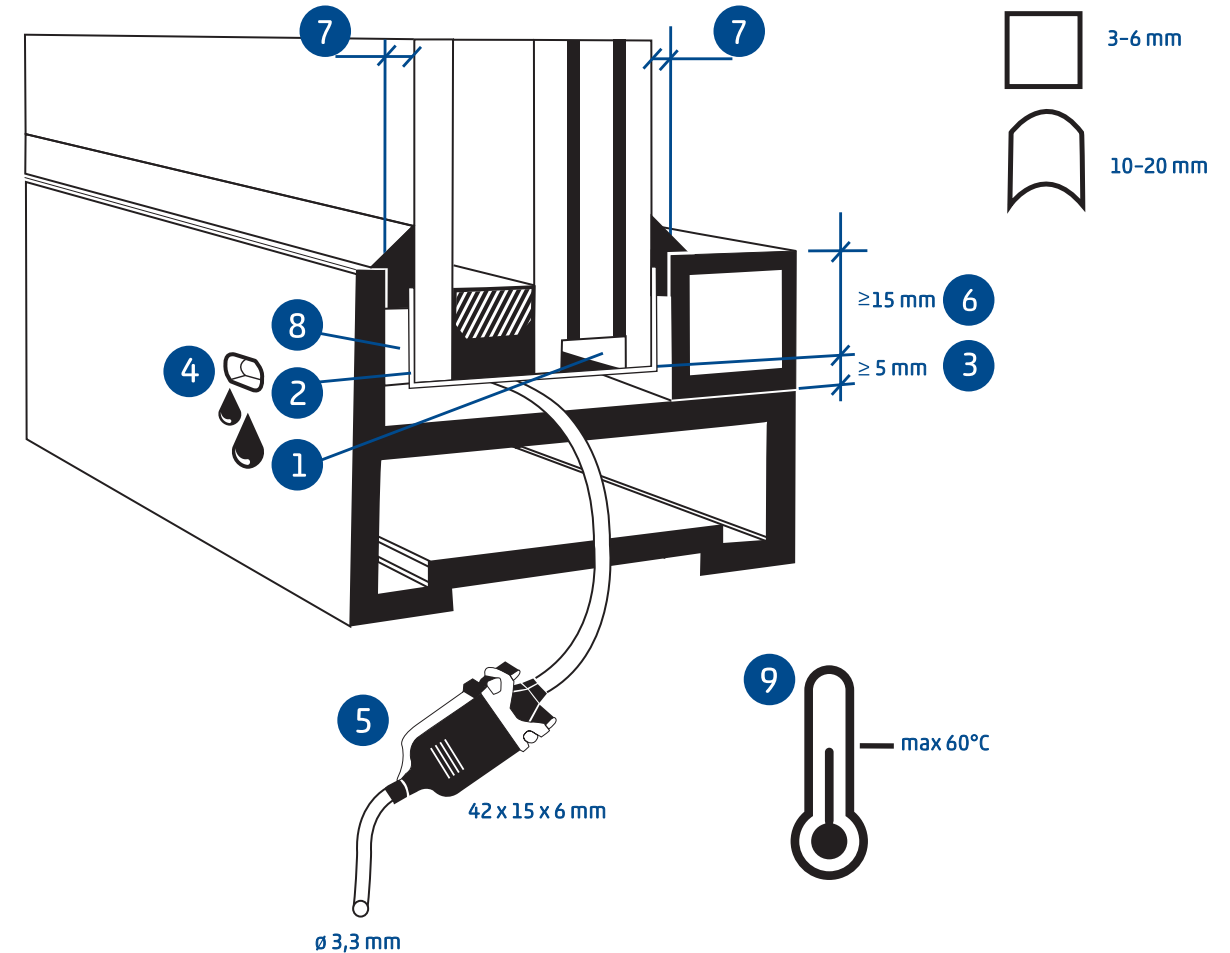

1 VISUAL CHECK:

The glass pane is to be checked for any damage and malfunctions. SILATEC panes have a circumferential cladding tape which may not suffer damage. Faulty panes may not be installed.

2 DIRECTION OF INSTALLATION:

All SILATEC panes have a direction of installation marked with a label. The direction of installation **MUST** be adhered to. Incorrect installation of the panes can result in the loss / reduction of the function and protective effect.

3 CHECK ALARM:

Every alarm glass is to be checked for its function (electrical resistance test) and for any damage before and after installation. Faulty alarm panes may not be installed.

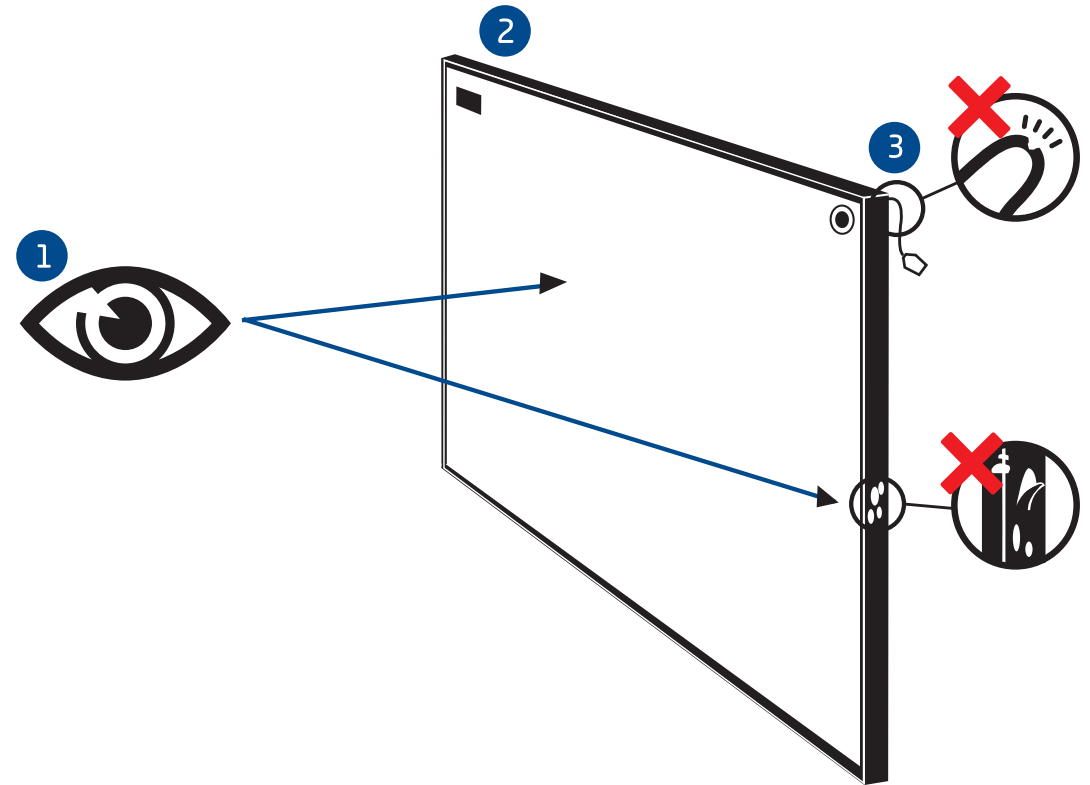

1 SETTING BLOCK

Deflects any forces into the frame and metal fitting. It must be non-ageing, long-term pressure resistant and material compatible (e.g. impregnated hard wood or a suitable plastic with 60°-80° Shore A) and must not damage the glass edge. It must lie flat in the rebate bottom. The glass pane must lie flat along its entire thickness. With a flat rebate bottom, a circumferential ventilated glazing rebate must be guaranteed (bridge setting block).

2 DISTANCE BLOCK

Guarantees the distance between the glass edge and the rebate bottom and ensures zero-stress installation. It has the same properties as the setting block.

3 CYLINDRICALLY CURVED PANES:

No forces may be allowed to impinge on cylindrically curved panes. They must be subject to zero stress on all sides, without pressure points in the glazing rebate room. The entire pane must be raised during installation in order to adjust otherwise the glass could break.

- T SETTING BLOCK
- T* A pane over 1.000 mm in width requires two setting blocks of min. 60 mm in length to be laid over the swivel bearings.
- D DISTANCE BLOCK
- D* Opening the window wings converts them into setting blocks
- D** Distance block shock-absorbing plastic

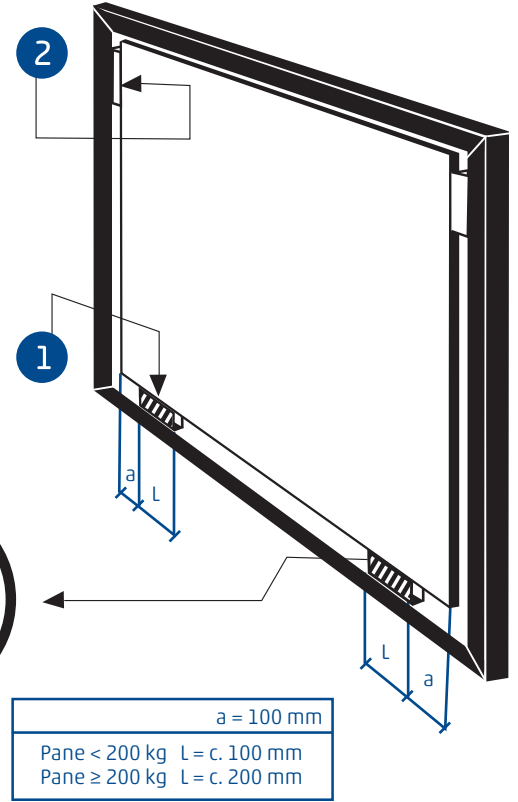
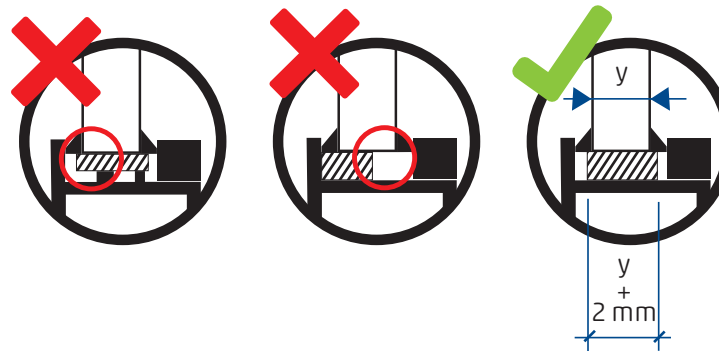
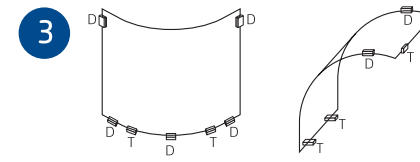
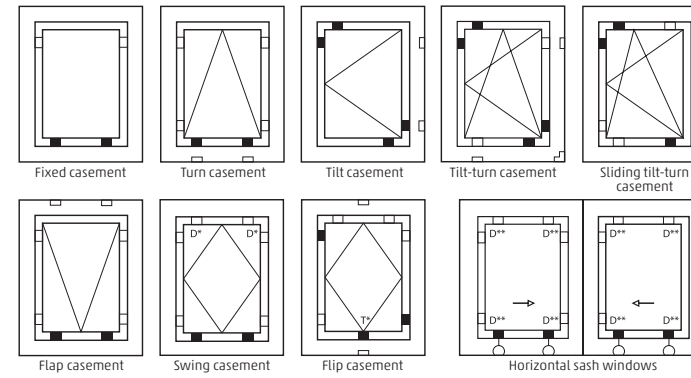

Comply with all country-specific guidelines, rules etc. for notification of break-ins. The guidelines for the installation of electrical systems and the VdS directives for burglar alarm systems apply.

- 1 **FUNCTIONAL TEST:** Every alarm glass is to be checked for its function (electrical resistance test) before fitting.
The **alarm line** has the greatest electrical resistance.
The **sabotage line** has the lowest electrical resistance.
Faulty alarm panes may not be installed.
- 2 **PLUG CONNECTION:** The plug connection and the extension cable are approval. Other connections (e.g. solders) are impermissible. The plug connection is preferably to be installed in the low-humidity upright glazing rebate room with the opening downwards. The cable and plug connection must not become damaged, jammed or kinked and must be installed in a non-tension fashion.
- 3 **EXTENSION CABLE:** Available lengths: 3 m, 6 m, 10 m
- 4 **MAX. CURRENT LOAD:** < 0.1 A through current strength

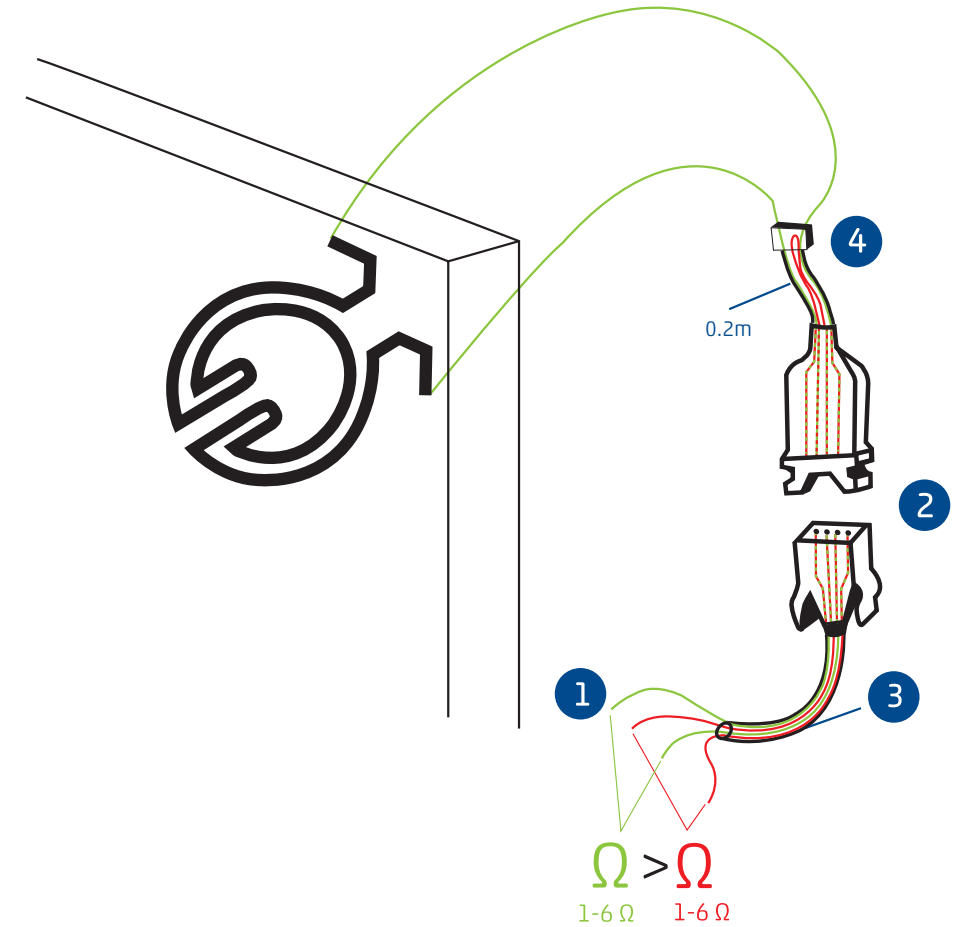

1 TRANSPORT ROUTES:

Pressure equalisation could be required on transport routes with extreme height differences and resulting differences in air pressure. If a height of 700m above sea level is exceeded, consultation is required with SILATEC.

2 STORAGE:

When storing multiple panes upon each other, the respective glass surfaces must not be in direct contact with each other. Use suitable spacers. The glass panes must not be stored outside and must be protected against rain, sunlight and soiling.

3 PROTECTIVE MEASURES:

We recommend protection of the panes after installation. The protective measures must not be permitted to damage the surface of the glass or contribute to the heating of the glass panes and must be removable without leaving a residue.

4 SEALANT:

We recommend neutrally linking silicone. Ensure material compatibility with the glazing and the frame.

5 GLASS CLEANING:

Use clean water or glass cleaner and a clean cloth. Sharp and hard objects such as blades or abrasive cleaners are not suitable for cleaning glass.

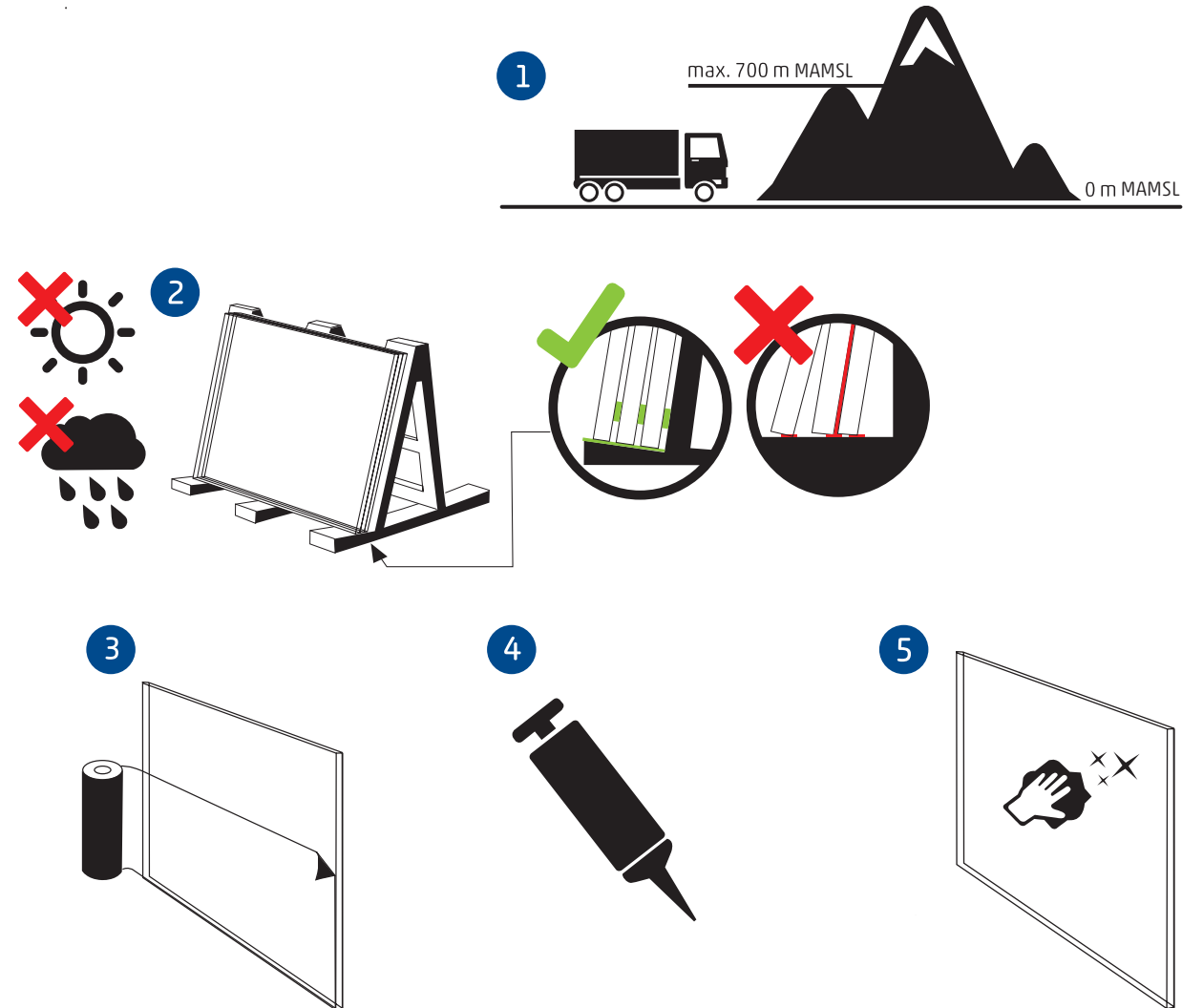

TAKE CARE (Tc)

The protection side (usually the room side) is made of plastic with a scratch-proof plastic surface coating and is to be handled with especial care.

The attack side is made of glass

Distortion can occur with angled viewing. Spectral colours can be visible at night and when using artificial light. This is not a ground for complaints.

Storage: Store in a dry, clean room. Do not store outside, in the rain or in direct sunlight.

Installation: Suction must not be applied to the glass pane on the protective film, as this does not have sufficient lifting capacity.

Joint: Only the following sealant brands may be used for the joining of the plastic side: Mumentive, Multisil.

A dry glazing with rubber seal or other seals are not permissible (material compatibility).

Cleaning: We recommend that you use a soft cotton cloth, lukewarm water and mild soap to remove coarse soiling. Do not use any alkali cleaning agents. Then rinse the pane with plenty of clean water and dry with a soft cotton cloth. Do not use any sharp-edged objects or abrasive cleaners, as these could irreparably scratch or damage the surface.

ANTI REFLECTIVE

SILATEC Anti Reflective is a non-reflective glass which is to be handled with especial care, as the glass surface is coated and sensitive.

Planning: As these panes are "hardly visible", design precautions must be taken to ensure that people do not run into the panes. Do not affix any labels or decorative film, as the coating could suffer damage when these are removed.

Storage

Installation: SILATEC Anti Reflective must be stored in a dry, clean room. Do not store outside or in a position exposed to rain or sun. Ensure that the coated glass surface is not damaged or soiled. Scratches are especially visible and cannot be polished out. Soiling on the site (e.g. from limescale, concrete or cement spray) must be prevented at all costs, as this could result in corrosion and irremovable stains. Should splashes reach the glass surface, clean these away immediately with plenty of clean water. Wear clean, suitable gloves and use a clean vacuum cleaner of a design which will not damage the surface.

Cleaning: SILATEC Anti Reflective should be cleaned regularly with plenty of clean water and a clean sponge or a soft cotton cloth. The cleaning water can be mixed with a neutral, non alkali, non-scouring wetting agent (e.g. Ajax, Sidolin, Pril).

Never use:

- Microfibre cloths (overly-aggressive cleaning method)
- Blades, steel wool, scrubbing sponges, paper cloths, hard cloths
- Alkali liquors (e.g. curd soap)
- Acids (e.g. hydrochloric acids, vinegar, lemon juice)
- Decalcifier (e.g. lemon juice)
- Degreasing agent (e.g. acetone, benzene)
- Substances containing ammonia or chlorine (e.g. Domestos)
- Solvents (e.g. alcohol, acetone)

CONVERSION TABLE					
Length					
... mm	x	0.03937	=	... inches	
				... inches	x 25.4 = ... mm
... cm	x	0.3937	=	... inches	
				... feet	x 30.48 = ... cm
... m	x	1.0936	=	... yards	
				... yards	x 0.9144 = ... m
Fläche					
... m ²	x	1.196	=	... yards ²	
				... yards ²	x 0.8361 = ... m ²
... m ²	x	11.111	=	... feet ²	
				... feet ²	x 0.09 = ... m ²
Weight					
... kg	x	2.2046	=	... pounds	
				... pounds	x 0.4536 = ... kg
... kg/m ²	x	0.1984	=	... pounds/feet ²	
				... pounds/feet ²	x 5.0403 = ... kg/m ²
... kg/m ²	x	1.8433	=	... pounds/yards ²	
				... pounds/yards ²	x 0.5425 = ... kg/m ²
Temprature					
... °C	x	1.8 + 32	=	... °Fahrenheit	
				... (°Fahrenheit - 32)	x 0.5555 = ... °C

